

MULTI-SIZE HOLE CUTTER

OPERATION MANUAL

LC-M8 maximum cutting size 163mm diameter

LC-XL8 maximum cutting size 260mm diameter

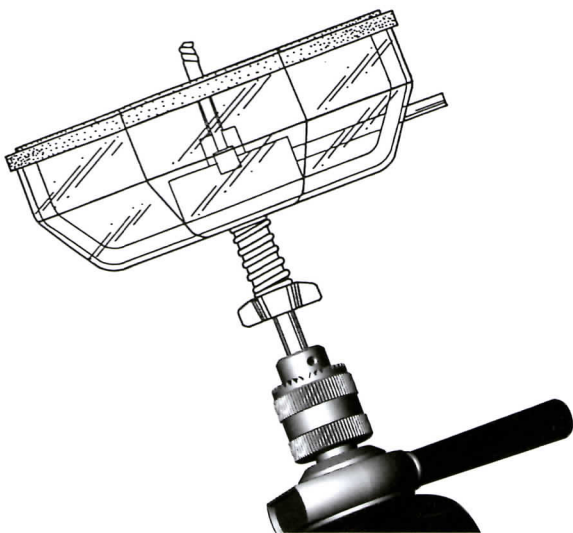

***PATENT:**

Germany:499 11 414.0.

United Kingdom:2088582

U.S.A.:29/114.548

Australia applying No.4028/1999

Chart of parts & code no.

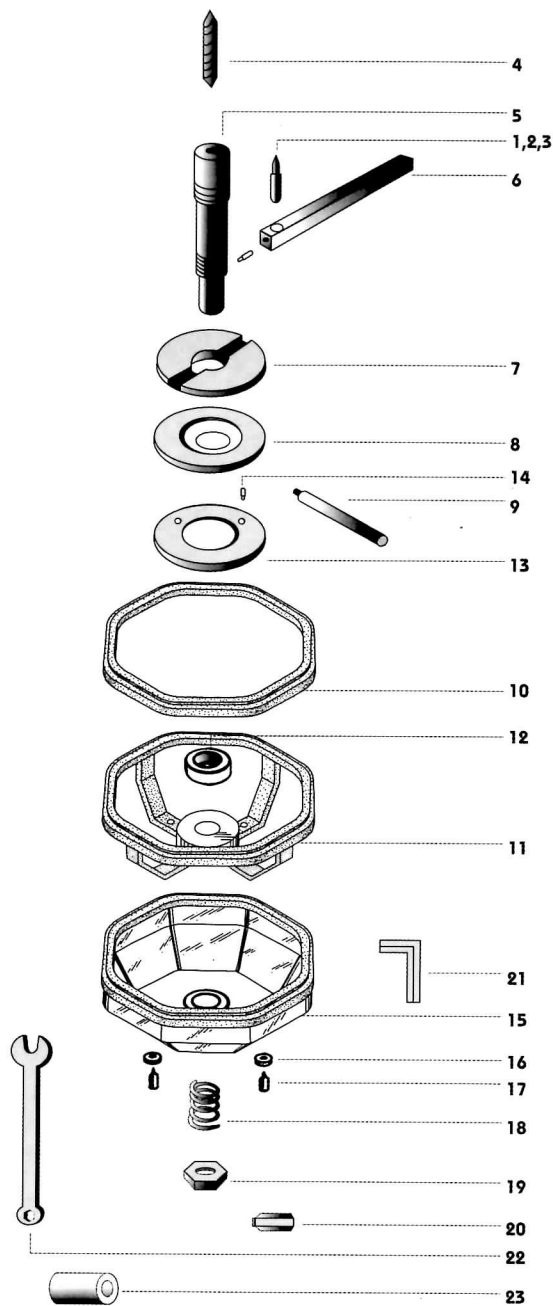

List of parts description

1. High speed steel blade for LC-M8, for cutting wood, plasterboard etc.
2. Tungsten Carbide tipped blade for LC-M8 and LC-XL8, for cutting metal.
3. High speed steel blade for LC-XL8. for cutting wood, plasterboard etc.
4. Drill bit
5. Upright axle
6. Ruler axle
7. Fixed disk
8. Adjustment Locking disk (Note left hand thread)
9. Adjusting rod
10. Rubber gasket
11. Support frame
12. Bearing
13. Bearing fixed disk
14. Screw
15. Transparent cover
16. Rubber washer
17. Screw
18. Spring
19. Hexagon nut
20. Balance bar (4 sizes)
21. Hexagonal wrench
22. Spanner
23. PU protection tube (fits over drill bit)

General introduction to parts

- A. Adjusts the cutting size
- B. Adjusts the cutting thickness
- C. Prevents movement of chips and dust
- D. Fixes the cutting centre

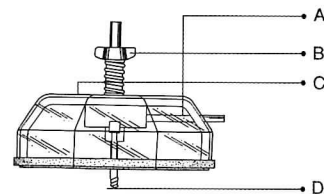

How to use the balance bar

Model LC-M8:

If the hole to be cut is between 80-100 mm dia., there is no need to use a balance bar.

If the hole to be cut exceeds 100mm dia., then use a bar detailed in the chart below:

Balance bar length	Cutting size (dia)
15mm	100 - 120mm
20mm	120 - 140mm
37mm	140 - 163mm
56mm	163mm

(see drawing A)

If the hole to be cut is less than 80mm dia., then use the balance bar on the opposite side (blade side) using a bar detailed in the chart below:

Balance bar length	Cutting size (dia)
15mm	70 - 80mm
20mm	60 - 70mm
37mm	45 - 60mm
56mm	30 - 45mm

(see drawing B)

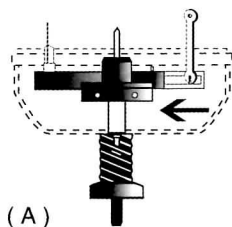

How to use the balance bar

Model LC-XL8:

If the hole to be cut is between 130-160 mm dia., there is no need to use a balance bar.

If the hole to be cut exceeds 160mm dia., then use a bar detailed in the chart below:

Balance bar length	Cutting size (dia)
60mm	160 - 200mm
80mm	200 - 240mm
100mm	240 - 254mm
110mm	254 - 260mm

(see drawing A)

If the hole to be cut is less than 130mm dia., then use the balance bar on the opposite side (blade side) using a bar detailed in the chart below:

Balance bar length	Cutting size (dia)
60mm	100 - 130mm
80mm	80 - 100mm
100mm	55 - 80mm
110mm	30 - 55mm

(see drawing B)

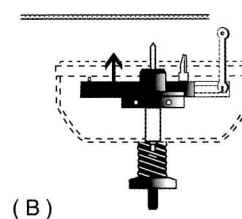

Cutting Instructions

Having decided on the size of hole and material to be cut, assemble ruler axle (6) blade and relevant balance bar together in the upright axle.

Hole Size adjustment

Method 1:

Hole cutter fitted in drill chuck (see fig C).

Support drill with one hand and use the adjusting rod (9) to loosen adjusting locking disk (8) which then allows ruler axle (6) to be slid to the desired size. (Note adjusting locking disk has a left hand thread). Fit rod into hole of disk and turn the bowl so that support frame contacts end of adjusting rod. When viewing open bowl from above turn bowl anti-clockwise to loosen locking disk and clockwise to tighten.

Method 2:

Adjusting using spanner (see fig D).

Using the adjusting rod as detailed in method 1, support the bowl and adjusting rod and use spanner supplied to turn upright axle when viewing open bowl from above. Turn axle clockwise to loosen and anti-clockwise to tighten adjusting locking ring.

Caution:

1. Ensure power is removed to drill before adjusting.
2. Ensure adjusting rod is removed prior to restoring power.
3. Blades are very sharp, take care when working near/cleaning or changing them.
4. For your safety do not attempt to cut holes without transparent cover fitted.
5. Ensure all parts are securely attached before cutting e.g. drill, blade, ruler axle (recheck if noise changes during cutting).

Cutting size (see fig E)

The scale set out on the ruler axle between blade and start of upright axle gives approximately dia in mm. An alternative method is to measure between outside edge of blade and side of drill, add 3mm and then double it to ascertain diameter.

Depth of cut can be restricted by tightening nut onto the spring.

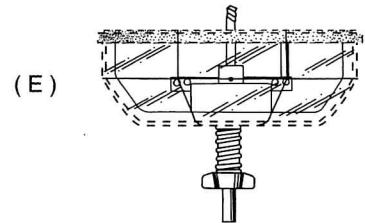
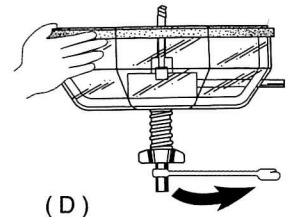
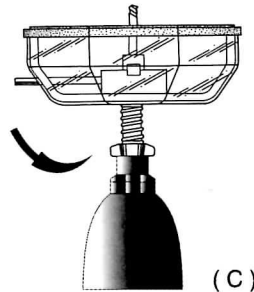

Operation instruction

- 1. Install the hole cutter securely in chuck of drill.**
- 2. Use adjusting rod to adjust for correct hole size.**
- 3. Position blade so that tallest part of blade is to outside and thin section cuts material.**
- 4. On Carbon tipped blade the tipped V should face forward to cut metal.**
- 5. Place drill bit to the centre of the hole you wish to cut and start drilling slowly to ensure position.**
- 6. Drill slowly through material, DO NOT press heavily. Stop drill before removing hole cutter from hole.**
- 7. Only use this hole cutter within its specification to ensure long life of this product and your safety.**

Hole cutting

- 1. Cutting hole sizes of up to 163mm (LC-M8) and 260mm (LC-XL8) in plaster board plywood acrylic sheet etc can be achieved up to 23mm deep. 45mm depth can be achieved when drilling from both sides is possible.**
- 2. Using Carbon steel blade, aluminium, brass and metal sheets can be cut up to 1mm deep.
Note approximate cuttings speeds for:
hole sizes of 115mm = 900 rpm
hole sizes of 200mm = 500 rpm.**
- 3. When cutting overhead (ceilings) use PU protection tube (23) over drill bit to stop hole centres dropping too far.**